

Description

Magnecraft General Purpose Relays

792 Control Series

DPDT 12 A; 4PDT 6 A and 3 A



UL listed when used with proper Magnecraft sockets



792 Clear Cover



792 Full-Feature Cover

Description

The 792 Plug-in Control relays offer clear or full-feature covers with multiple mounting options and accessories; 4PDT models save valuable space while adding increased functionality.

Feature	Benefit
12 A / 6 A / 3 A switching current	Ideal for various automation panels and controls
Clear or full-feature cover options	Full-feature covers include LED indicator and locking test button to facilitate maintenance and expedite commissioning
DPDT and 4PDT contact options	Simultaneously control 2 or 4 separate circuits
Socket mount option	Simplifies installation and maintenance while also allowing the use of protection modules, hold-down clips and other accessories
Gold-flashed contacts	Reduces contact oxidation and increases shelf life
Mechanical flag indicator	Standard feature that displays relay status during testing or operation without having to power the relay

Contact Rating	Contact Configuration	Nominal Coil Voltage	Coil Resistance (Ω)	Contacts	Part Number: Clear Cover	Part Number: Clear Cover with LED	Part Number: Full-Feature Cover
3 A	4PDT	12 Vac	44	Low Level Bifurcated	792XDX3C-12A	792XDX3CL-12A	792XDX3M4L-12A
		24 Vac	177		792XDX3C-24A	792XDX3CL-24A	792XDX3M4L-24A
		48 Vac	708		792XDX3C-48A	792XDX3CL-48A	792XDX3M4L-48A
		120 Vac	3630		792XDX3C-120A	792XDX3CL-120A	792XDX3M4L-120A
		240 Vac	17720		792XDX3C-240A	792XDX3CL-240A	792XDX3M4L-240A
		12 Vdc	160		792XDX3C-12D	792XDX3CL-12D	792XDX3M4L-12D
		24 Vdc	640		792XDX3C-24D	792XDX3CL-24D	792XDX3M4L-24D
		48 Vdc	2560		792XDX3C-48D	792XDX3CL-48D	792XDX3M4L-48D
		110 Vdc	13440		792XDX3C-110D	792XDX3CL-110D	792XDX3M4L-110D
		12 A	DPDT		12 Vac	44	Standard
24 Vac	177			792XBXC-24A	-	792XBXM4L-24A	
48 Vac	708			792XBXC-48A	-	792XBXM4L-48A	
120 Vac	3630			792XBXC-120A	-	792XBXM4L-120A	
240 Vac	17720			792XBXC-240A	-	792XBXM4L-240A	
12 Vdc	160			792XBXC-12D	-	792XBXM4L-12D	
24 Vdc	640			792XBXC-24D	-	792XBXM4L-24D	
48 Vdc	2560			792XBXC-48D	-	792XBXM4L-48D	
110 Vdc	13440			792XBXC-110D	-	792XBXM4L-110D	
6 A	4PDT			12 Vac	44	Standard	
		24 Vac	177	792XDXC-24A	792XDXCCL-24A		792XDXM4L-24A
		48 Vac	708	792XDXC-48A	792XDXCCL-48A		792XDXM4L-48A
		120 Vac	3630	792XDXC-120A	792XDXCCL-120A		792XDXM4L-120A
		240 Vac	17720	792XDXC-240A	792XDXCCL-240A		792XDXM4L-240A
		12 Vdc	160	792XDXC-12D	792XDXCCL-12D		792XDXM4L-12D
		24 Vdc	640	792XDXC-24D	792XDXCCL-24D		792XDXM4L-24D
		48 Vdc	2560	792XDXC-48D	792XDXCCL-48D		792XDXM4L-48D
		110 Vdc	13440	792XDXC-110D	792XDXCCL-110D		792XDXM4L-110D

Part Number Explanation

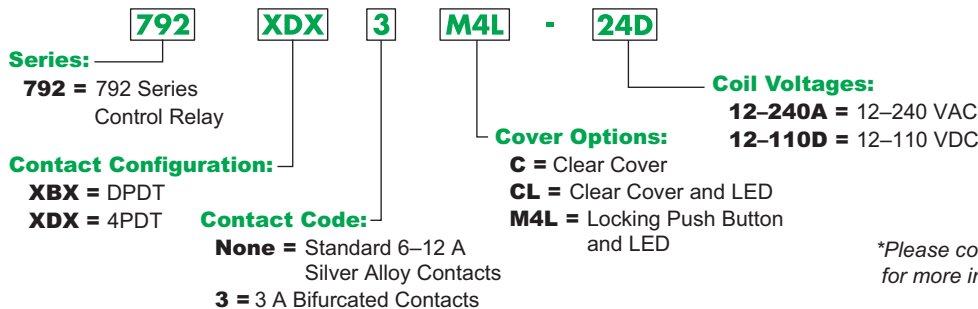

*Please contact Customer Service for more information (847-441-2540).

Specifications

Part Number	792XBX
Contact Characteristics	
Terminal Style	Blade
Contact Material	Silver Alloy
Contact Configuration	DPDT
Maximum Switching Current	12 A
Maximum Switching Voltage	IEC: 250 Vac / 28 Vdc UL/CSA: 300 Vac / 30 Vdc
Rated Operational Current (Conforming to IEC AC-1 and DC-1)	NO: 12 A at 250 Vac, NC: 6 A at 250 Vac NO: 12 A at 28 Vdc, NC: 6 A at 28 Vdc
Rated Operational Current (Conforming to UL)	Resistive: 12 A at 277 Vac, 100k cycles Resistive: 12 A at 120 Vac, 200k cycles Resistive: 12 A at 30 Vdc, 100k cycles Motor: 1/2 HP at 120 Vac, 6k cycles Motor: 1 HP at 277 Vac, 6k cycles B300 PILOT DUTY, 6k cycles
Minimum Switching Requirement	10 mA at 17 Vdc
Coil Characteristics	
Maximum Operating Voltage	110% (AC / DC)
Maximum Pickup Voltage	80% (AC); 80% (DC)
Drop-out Voltage Threshold	15% (AC); 10% (DC)
Average Consumption	0.9–1.2 VA (AC); 0.8–1.1 W (DC)
General Characteristics	
Electrical Life at Rated Load	200,000 operations (where stated)
Mechanical Life (Unpowered)	10,000,000 operations
Operating Time	25 ms max. at 80% rated coil voltage 20 ms max. at 100% rated coil voltage
Release time	20 ms max. (DC) 35 ms max. (AC)
Impulse Withstand Voltage	4 kV (1.2 / 50 μ s)
Dielectric Strength - Between Coil and Contact (AC)	2000 V(rms)
Dielectric Strength - Between Poles (AC)	2000 V(rms)
Dielectric Strength - Between Contacts (AC)	1300 V(rms)
Ambient Air Temperature around the Device - Storage	-40 to +85 °C (-40 to +185 °F)
Ambient Air Temperature around the Device - Operation	-40 to +55 °C (-40 to +131 °F)
Vibration Resistance - In Operation	3 g-n at 35–150 Hz
Vibration Resistance - Not Operating	5 g-n at 35–150 Hz
Shock Resistance - In Operation	10 g-n
Shock Resistance - Not Operating	30 g-n
Degree of Protection (Housing Only)	IP 40
Weight	37 g (1.31 oz)
Agency Approvals	UL with socket, UR (E164862), CE, CSA (225619), RoHS

Note: Actual product performance may vary depending on application and environmental conditions.

Specifications (continued)

Part Number	792XDX	792XDX3
Contact Characteristics		
Terminal Style	Blade	Blade
Contact Material	Silver Alloy	Bifurcated
Contact Configuration	4PDT	4PDT
Maximum Switching Current	6 A	3 A
Load Type	Standard	Low Level
Maximum Switching Voltage	300 V	300 V
Rated Operational Current (Conforming to IEC AC1 and DC1)	NO: 6 A at 250 Vac, NC: 3 A at 250 Vac NO: 6 A at 28 Vdc, NC: 3 A at 28 Vdc	NO: 2 A at 250 Vac, NC: 1 A at 250 Vac NO: 2 A at 28 Vdc, NC: 1 A at 28 Vdc
Operational Current (Conforming to UL)	Resistive: 6 A at 277 Vac, 200k cycles Resistive: 8 A at 120 Vac, 200k cycles Resistive: 8 A at 30 Vdc, 200k cycles Motor: 1/3 HP at 120 Vac, 6k cycles Motor: 1/2 HP at 277 Vac, 6k cycles Pilot Duty: B300, 6k cycles	General Purpose: 3 A at 240–277 Vac General Purpose: 3 A at 120 Vac Resistive: 3 A at 30 Vdc Motor: 1/16 HP (2.8 A FLA) at 120 Vac Pilot Duty: 5 A make, 0.5 A break, 3 A continuous at 120 Vac
Minimum Switching Requirement	10 mA at 17 Vdc	3 mA at 5 Vdc
Coil Characteristics		
Maximum Operating Voltage	110% (AC / DC)	110% (AC / DC)
Maximum Pickup Voltage	80% (AC); 80% (DC)	80% (AC); 80% (DC)
Drop-out Voltage Threshold	15% (AC); 10% (DC)	15% (AC); 10% (DC)
Average Consumption	0.9–1.2 VA (AC); 0.8–1.1 W (DC)	0.9–1.2 VA (AC); 0.8–1.1 W (DC)
General Characteristics		
Electrical Life at Rated Load	200,000 operations (where stated)	100,000 (gen. purpose load) operations
Mechanical Life (Unpowered)	10,000,000 operations	10,000,000 operations
Operating Time	25 ms max. at 80% rated coil voltage 20 ms max. at 100% rated coil voltage	25 ms max. at 80% rated coil voltage 20 ms max. at 100% rated coil voltage
Release time	20 ms max. (DC) 35 ms max. (AC)	20 ms max. (DC) 35 ms max. (AC)
Impulse Withstand Voltage	2.5 kV (1.2 / 50 μs)	2.5 kV (1.2 / 50 μs)
Dielectric Strength - Between Coil and Contact (AC)	2000 V(rms)	2000 V(rms)
Dielectric Strength - Between Poles (AC)	1600 V(rms)	1600 V(rms)
Dielectric Strength - Between Contacts (AC)	1300 V(rms)	1300 V(rms)
Ambient Air Temperature around the Device - Storage	-40 to +85 °C (-40 to +185 °F)	-40 to +85 °C (-40 to +185 °F)
Ambient Air Temperature around the Device - Operation	-40 to +55 °C (-40 to +131 °F)	-40 to +55 °C (-40 to +131 °F)
Vibration Resistance - In Operation	3 g-n at 35–150 Hz	3 g-n at 35–150 Hz
Vibration Resistance - Not Operating	5 g-n at 35–150 Hz	5 g-n at 35–150 Hz
Shock Resistance - In Operation	10 g-n	10 g-n
Shock Resistance - Not Operating	30 g-n	30 g-n
Degree of Protection (Housing Only)	IP 40	IP 40
Weight	37 g (1.31 oz)	37 g (1.31 oz)
Agency Approvals	UL with socket, UR (E164862), CE, CSA (225619), RoHS	

Note: Actual product performance may vary depending on application and environmental conditions.

Dimensions — inches (millimeters)

Clear Cover Dimension

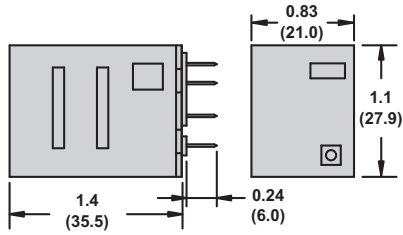

Full-Feature Cover Dimension

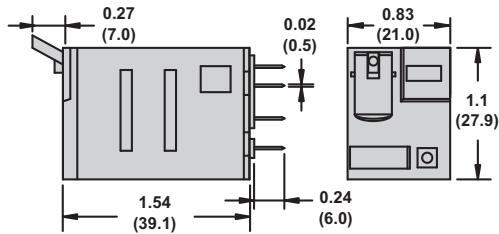

Wiring Diagrams

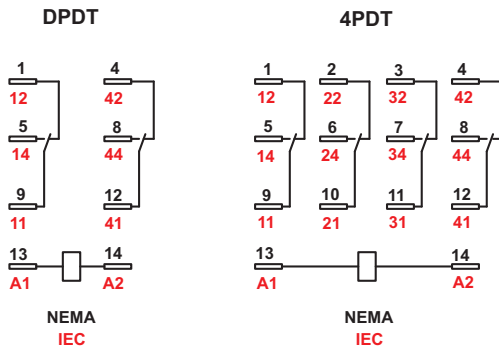

Magnecraft General Purpose Relays

792 Control Series Accessories



Description

Optional sockets offer customizable, Fingersafe™ solutions including protection modules, hold-down clips, and ID tags. Sockets are DIN rail and panel mount compatible.

Relay Accessories

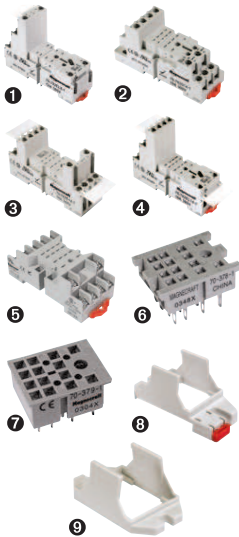

Description	Function	For Use With Relays	Pkg. Min.	Standard Part Number
Socket 1	DIN/Panel mount with elevator terminals	792XBX	10	70-782EL8-1
Socket 2	DIN/Panel mount with screw terminals and clamping plates	792XBX / 792XDX	10	70-782D14-1
Socket 3	DIN/Panel mount with rising elevator box terminals	792XBX / 792XDX	10	70-782E14-1
Socket 4	DIN/Panel mount with elevator terminals	792XBX / 792XDX	10	70-782EL14-1
Socket 5	DIN/Panel mount with screw terminals and clamping plates	792XDX	10	70-461-1
Socket 6	Solder terminals for chassis mount	792XDX	10	70-378-1
Socket 7	Printed circuit terminals for PCB mount	792XDX	10	70-379-1
Adapter 8	Mount directly to DIN rail	792XBX / 792XDX	10	16-782C
Adapter 9	Mount directly to panel	792XBX / 792XDX	10	16-782C1

Socket Accessories



Description	Function	For Use With Sockets	Coil Voltage	Pkg. Min.	Standard Part Number
Metal Spring Clip 1	Secures relay in socket	70-782D14-1, 70-782E14-1, 70-782EL14-1, 70-782EL8-1	-	10	16-782SC
Plastic Hold-Down Clip 2	Secures relay in socket or ejects relay off socket		-	10	16-782PC-1
Write-on tag 3	Small Write-on tag	-	-	10	16-782FT-1
Write-on tag 4	Write-on tag for 16-782PC-1 Hold-down Clip	-	-	10	16-700ST-1
Extruded Aluminum DIN Rail, 39.37" (1000 mm) 5	Quick installation and removal of sockets	70-782D14-1, 70-782E14-1, 70-782EL14-1, 70-782EL8-1	-	10	16-700DIN
DIN Rail End Clip 5	Holds sockets firmly in place on DIN rail	-	-	10	16-DCLIP-1
Insulated Coil Bus Jumper System 6	Wireless socket connection	70-782EL8-1, 70-782EL14-1	-	10	16-782CBJ-1
Small Socket Module	Protection Diode (Protects external drive circuitry from inductive voltages)	70-782D14-1, 70-782E14-1, 70-782EL14-1, 70-782EL8-1	6 to 250 Vdc	10	70-BSMD-250
Small Socket Module 7	LED Indicator (Provides coil status at a glance)		24 Vac/Vdc	10	70-BSMLG-24
Small Socket Module	MOV Suppressor (Protects from damaging electrical spikes)		120 Vac/Vdc	10	70-BSMM-120
			24 Vac/Vdc	10	70-BSMM-24
			240 Vac/Vdc	10	70-BSMM-240

Note: Use of LED socket module may increase coil power draw by up to 10%.